

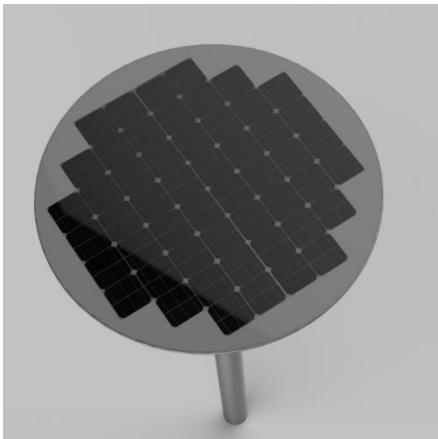

15 Watt Integrated Solar Street Light (AT8901)

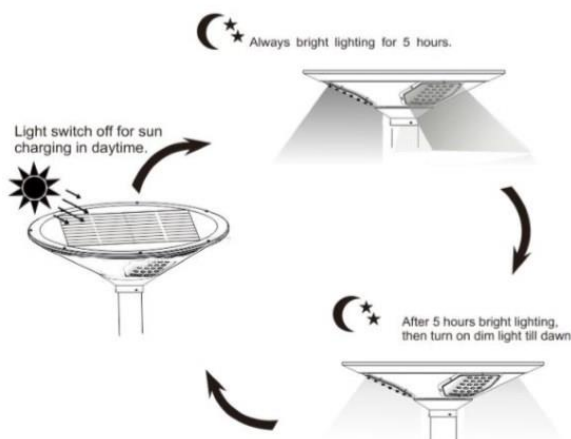

How's the light working?



Product Advantage:

- Professional design team develop, put solar panel, led chip, controller, battery, human induction in one box.
- Intelligent charge and discharge management, Charge-discharge dual protection and intelligent equalization technology, Cycle times more than 2000 times
- Smart remote control, With UVA(unmanned aerial vehicle) remote control, remote control long distance, bring high corrosion resistance, Four lighting modes can be set
- LED chip max can reach 220LM/W, more than double the average brightness of an ordinary LED light source, 140 degree view angle, bring same lighting results with shorter pole

Product Parameters:

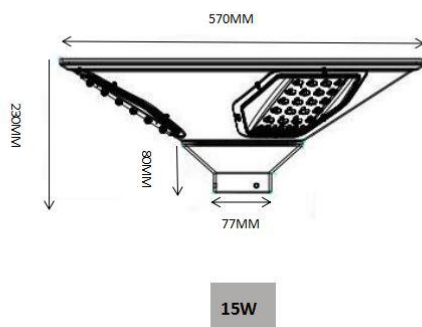

ITEM NO.	AT8901
Solar Panel	Monocrystal Silicon 18V/30W
Battery	Lithium battery 12V 14.4AH
LED color	Bridgelux 3030 /4500-6500K/72PCS
Material	High-end aluminum alloy + outdoor
Dimensions	57.0X57.0X23.0CM
Charge time	>8 hours
Work time	12 hours/day, support 2 rainy and cloudy
Mounting Height	3~4 M
Weight	7.0 KG
Working Temperature	-25℃ — +65℃
Installation Diameter	Φ70-75mm (suggest)
Warranty	2 Years